

DOCUMENTACIÓN TÉCNICA



Ref.: BMR06

Mesa Picnic



Madera de pino tratada en autoclave nivel IV
Tornillería de acero inoxidable
Tablones de 2000x140x35



ALZADO

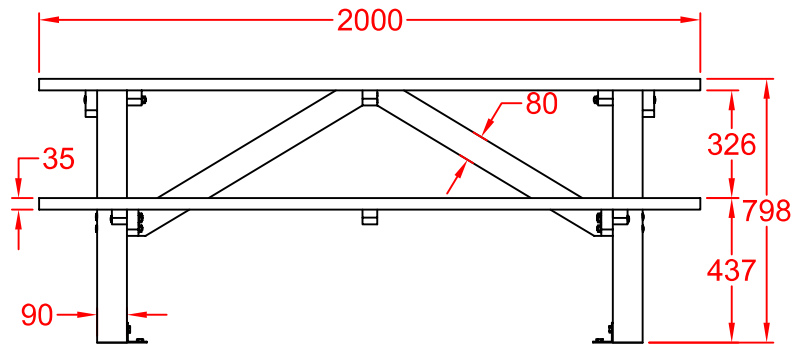

ALZADO

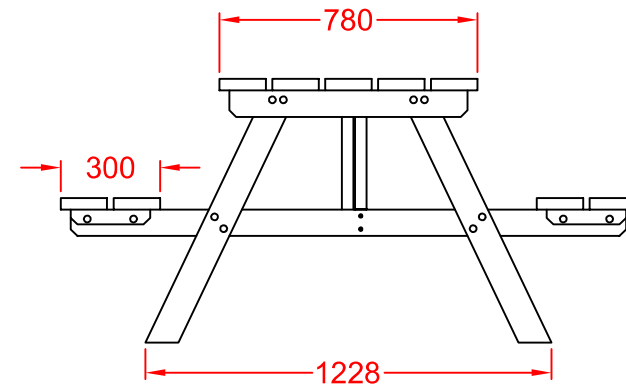

PLANTA

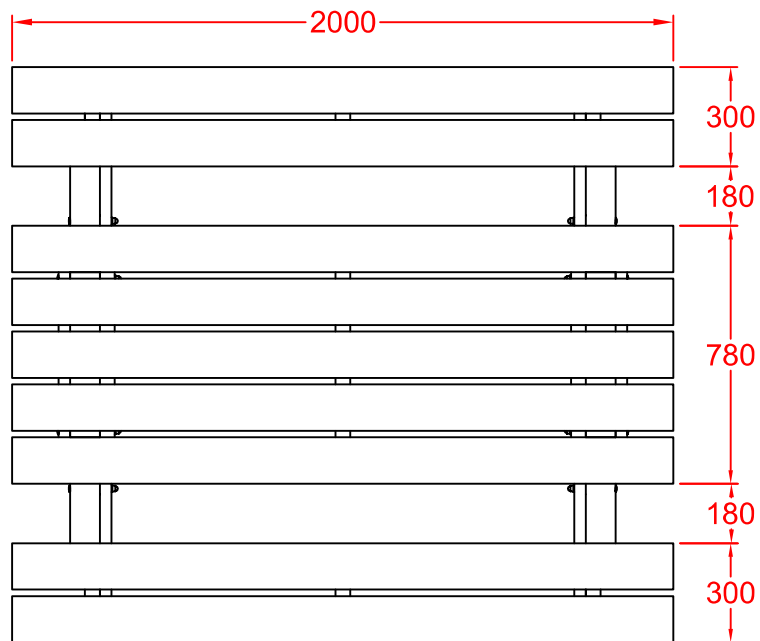

Ref:	Cantidad	Designación	Material	Dimensiones
Dibujado		PLANO 1 VISTAS GENERALES	Ref: BMR06	
Revisado				
Aprobado				
Descripción:		Escala:	Peso:	
MESA PICNIC		Fecha:	05-12-16	

ESQUEMA DE CIMENTACIÓN PARA CASOS EN LOS QUE VA EN ARENERO

E:2/1

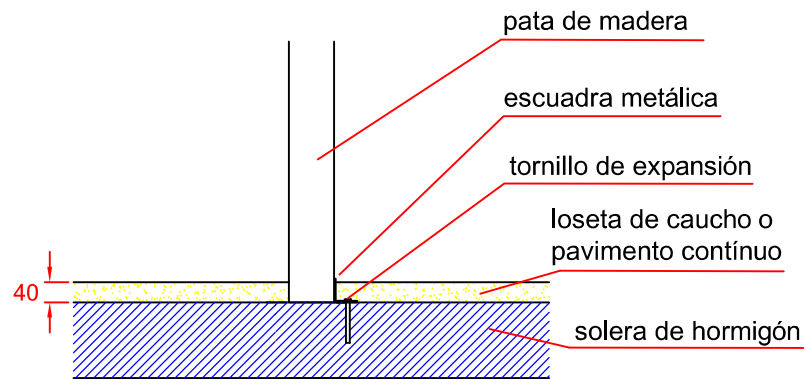

PLANTA CIMENTACIÓN

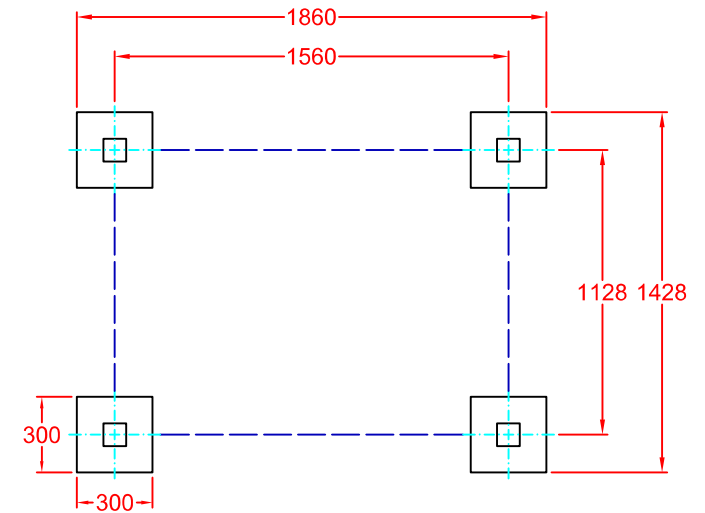

ESQUEMA DE CIMENTACIÓN PARA CASOS EN LOS QUE VA ATORNILLADO SOBRE SOLERA DE HORMIGÓN

E:2/1

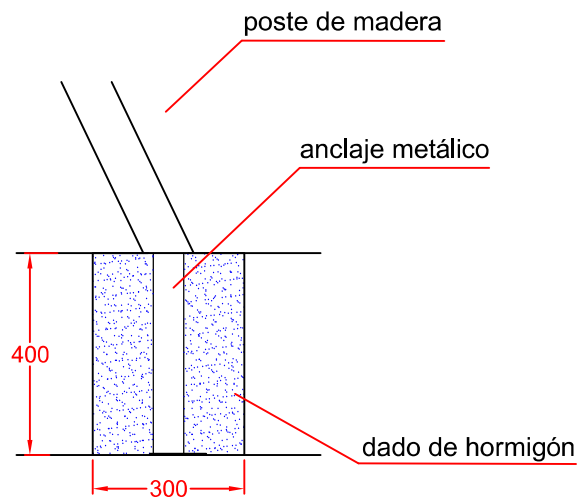

Ref:	Cantidad	Designación	Material	Dimensiones
Dibujado		PLANO 2 CIMENTACIÓN Y ANCLAJES	Ref: BMR06	
Revisado				
Aprobado				
Descripción:		Escala:	Peso:	
MESA PICNIC		Fecha: 05-12-16		