

DOCUMENTACIÓN TÉCNICA

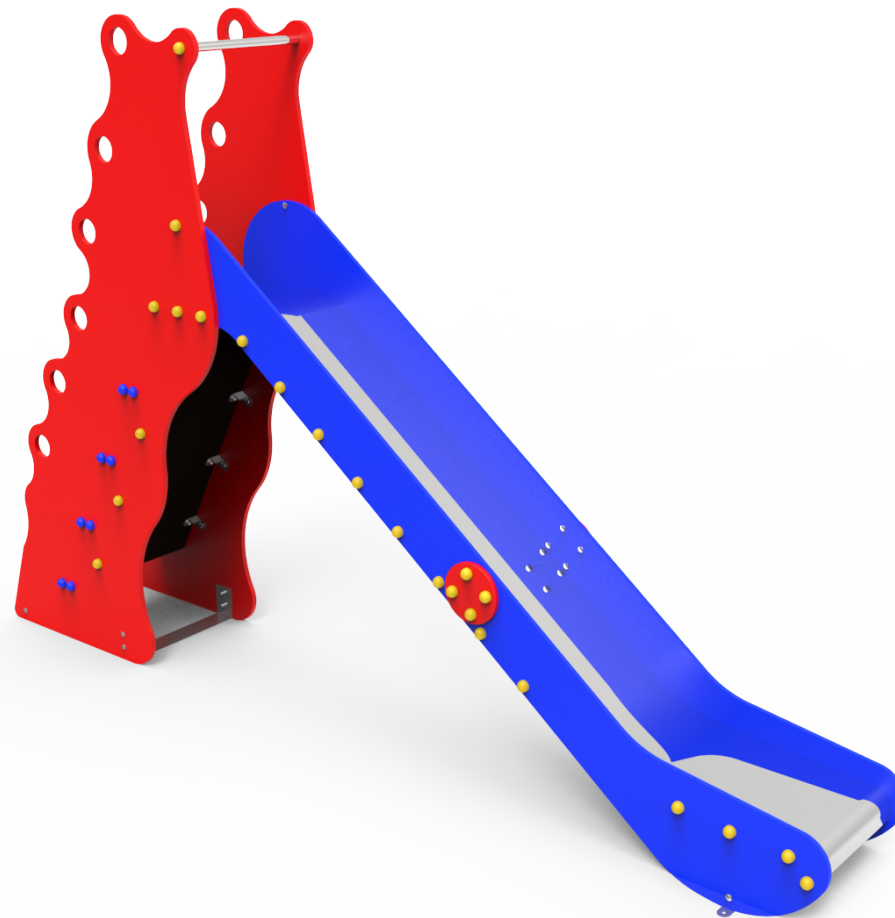
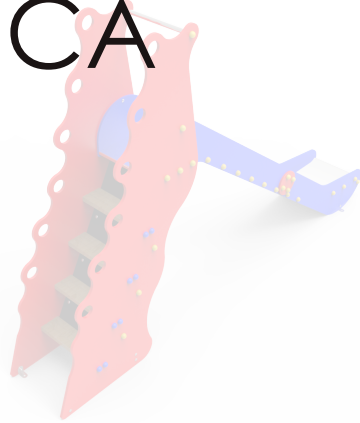

Ref.: TBG01

Tobogán "Gredos"

UNE-EN 1176 -1:2018

UNE-EN 1176 -3:2018



Altura libre de caída: 1,36 m
Edad recomendada de uso: a partir de 3 años
Componentes plásticos: Polietileno de alta densidad con protección UV
Rampa de tobogán: acero inoxidable
Tubo superior: acero inoxidable
Tornillería protegida con tapones de polipropileno

ALZADO

PERFIL

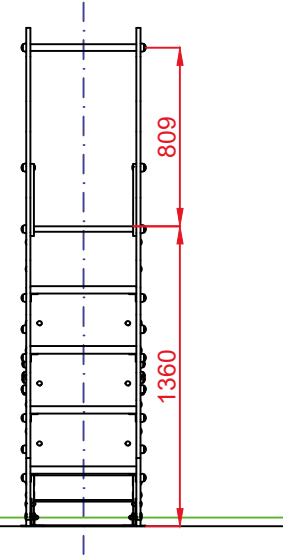
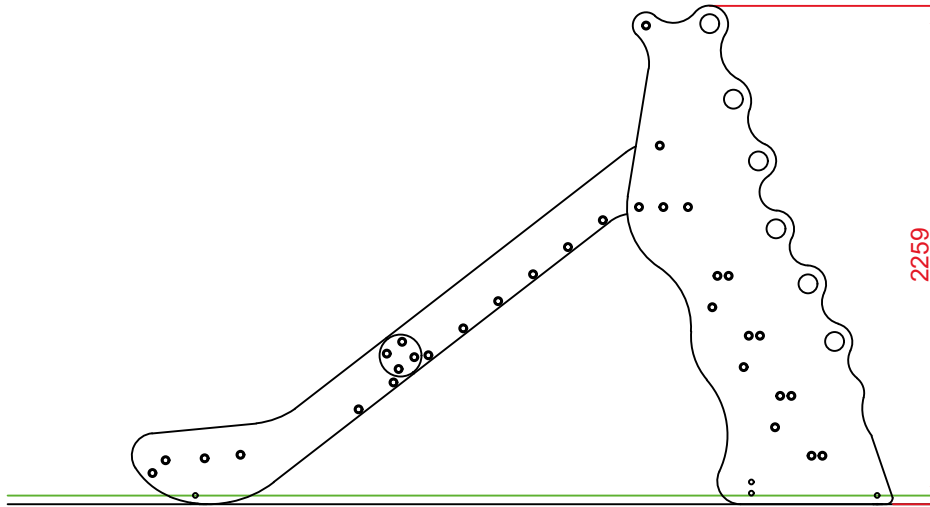

ÁREA DE SEGURIDAD
Superficie= 18.37 m²
E: 1/2

PLANTA

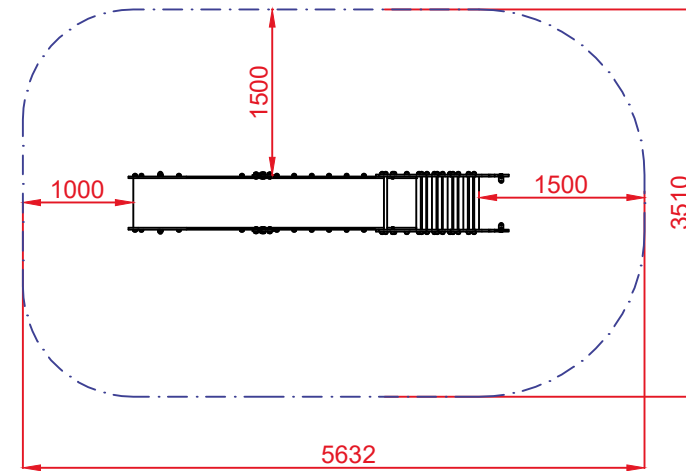
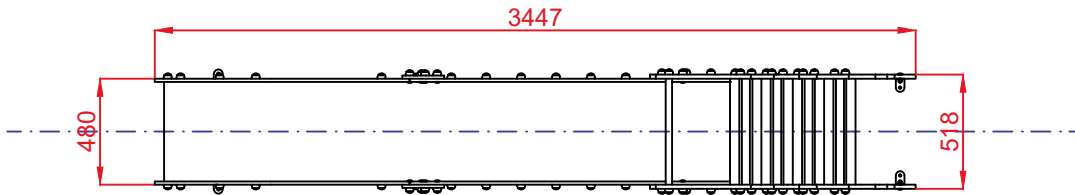

| | | | | |
|-------------------------------------|--|------------------|----------------|------------|
| Dibujado | | PLANO 1 | | Ref: TBG01 |
| Revisado | | VISTAS GENERALES | | |
| Aprobado | | | | |
| Descripción: TOBOGÁN "GREDOS" | | Escala: | Nº Hoja 2/4 | |
| | | Fecha: | 07/05/2019 | |

DETALLES CIMENTACIÓN

ESQUEMA DE CIMENTACIÓN
EN ARENA
E: 2/1

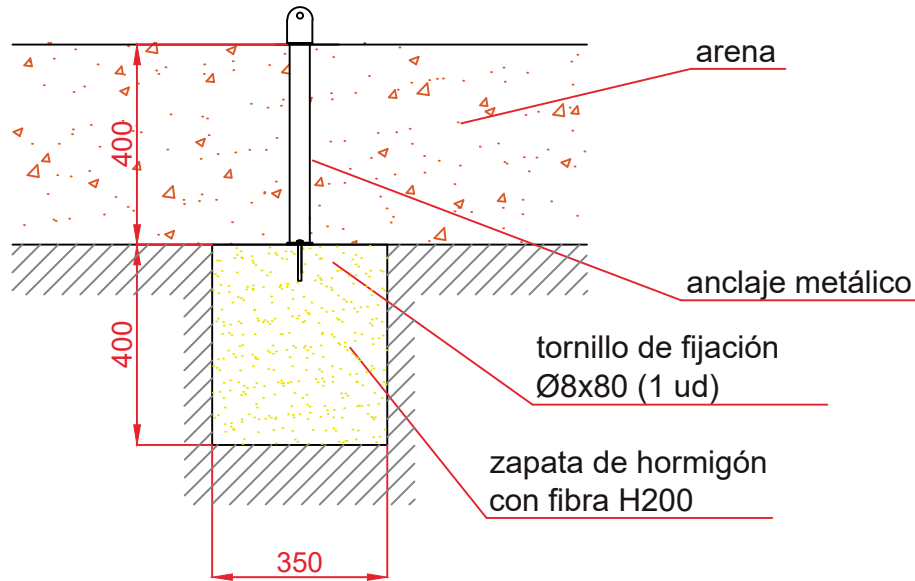

PLANTA CIMENTACIÓN

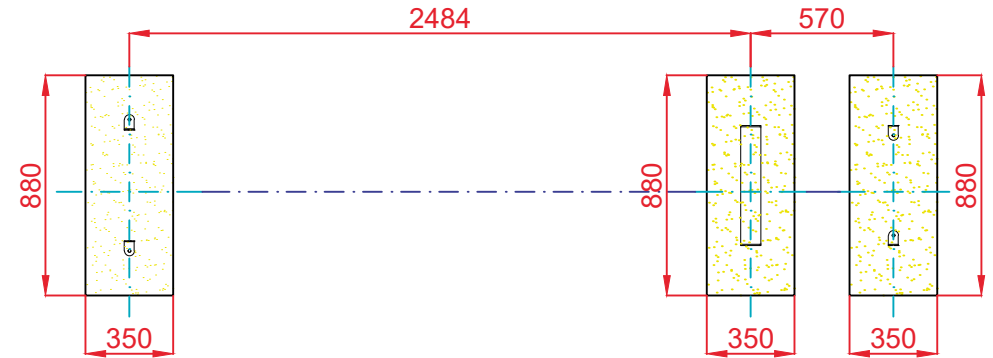

ESQUEMA DE CIMENTACIÓN
EN HORMIGÓN
E: 2/1

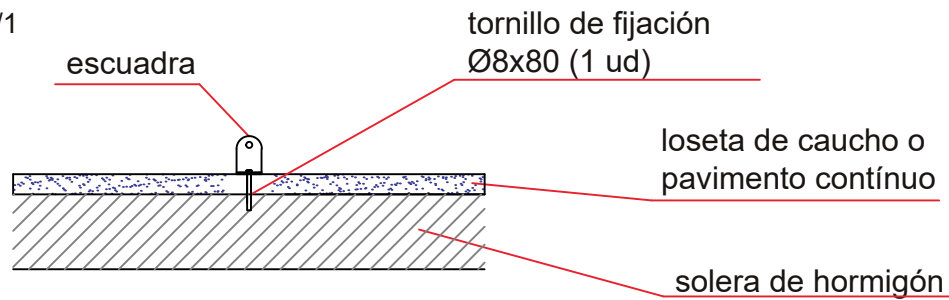

| | | | | |
|---------------------|--|-----------------------------------|------------|------------|
| Dibujado | | PLANO 2 CIMENTACIÓN Y ANCLAJES | | Ref: TBG01 |
| Revisado | | | | |
| Aprobado | | | | |
| Descripción: | | Escala: | Nº Hoja | |
| TOBOGÁN "GREDOS" | | | 3/4 | |
| | | Fecha: | 07/05/2019 | |

ALZADO

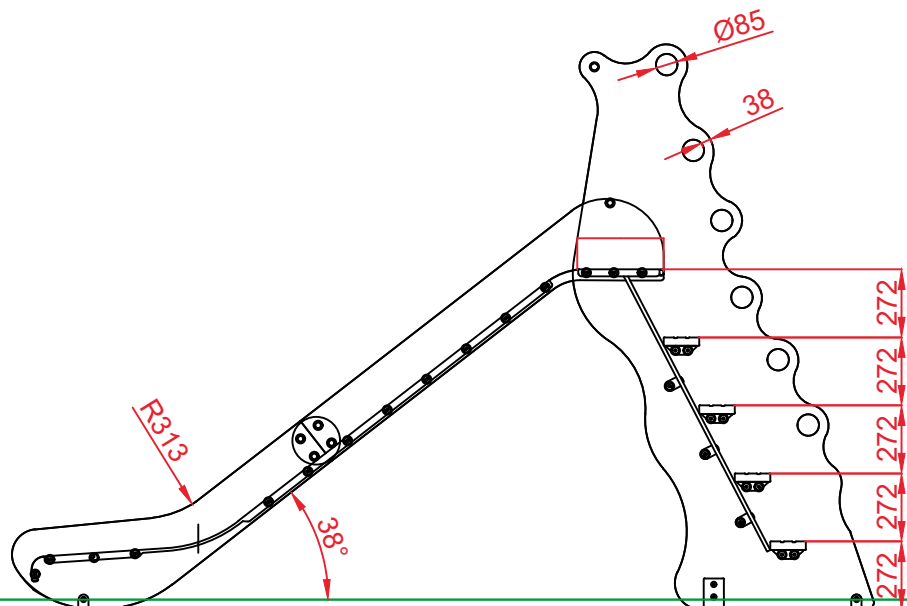

PERFIL

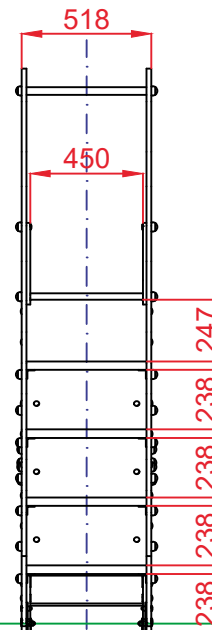

PLANTA

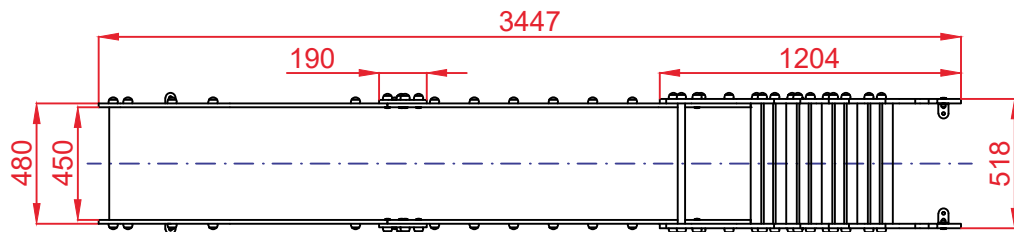

| | | | | |
|---------------------|--|------------------------------|------------|------------|
| Dibujado | | PLANO 3 VISTAS DE DETALLE | | Ref: TBG01 |
| Revisado | | | | |
| Aprobado | | | | |
| Descripción: | | ESCALA: | Nº Hoja | |
| TOBOGÁN "GREDOS" | | | 4/4 | |
| | | Fecha: | 07/05/2019 | |