

DOCUMENTACIÓN TÉCNICA

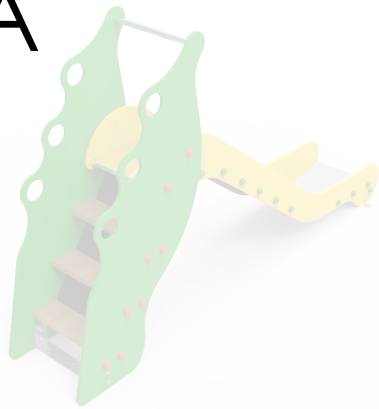

Ref.: TBG02

Tobogán “Manzanares”

UNE-EN 1176 -1:2018

UNE-EN 1176 -3:2018



Altura libre de caída: 0,90 m
Edad recomendada de uso: a partir de 3 años
Componentes plásticos: Polietileno de alta densidad con protección UV
Rampa de tobogán: acero inoxidable
Tubo superior: acero inoxidable
Tornillería protegida con tapones de polipropileno

ALZADO

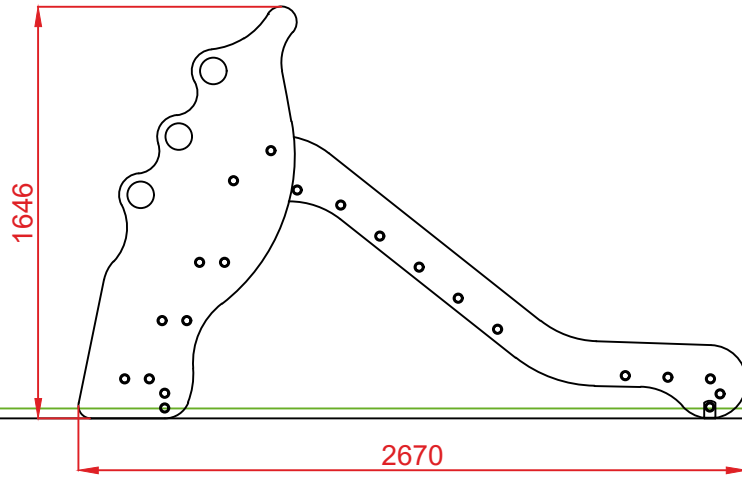

PERFIL

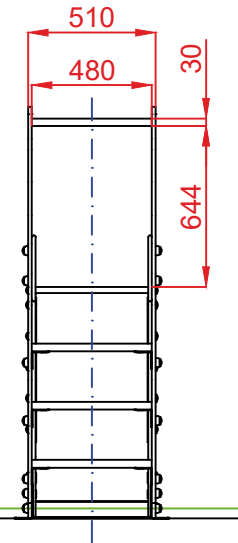

PLANTA

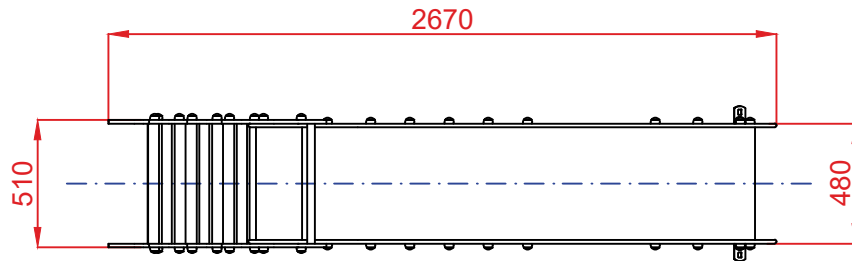

ÁREA DE SEGURIDAD
Superficie= 15.89 m²
E: 1/2

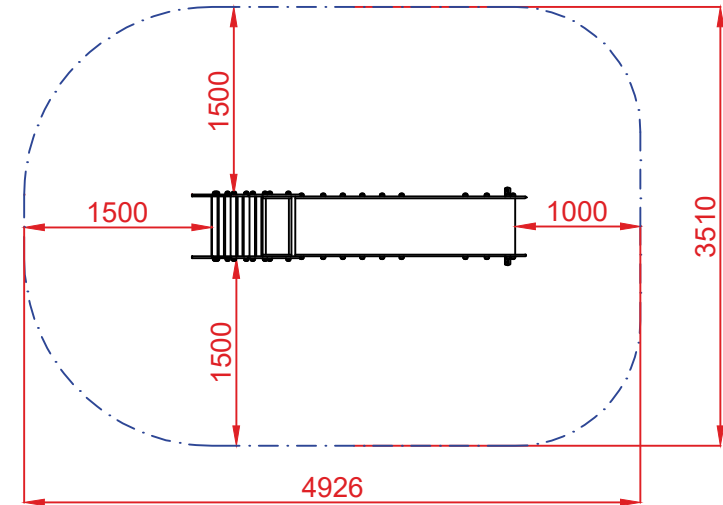

Dibujado		PLANO 1 VISTAS GENERALES	Ref: TBG02	
Revisado				
Aprobado				
Descripción:		TOBOGÁN "MANZANARES"	Escala:	Nº Hoja 2/4
			Fecha:	08/05/2019

DETALLES CIMENTACIÓN

ESQUEMA DE CIMENTACIÓN
EN ARENA
E: 2/1

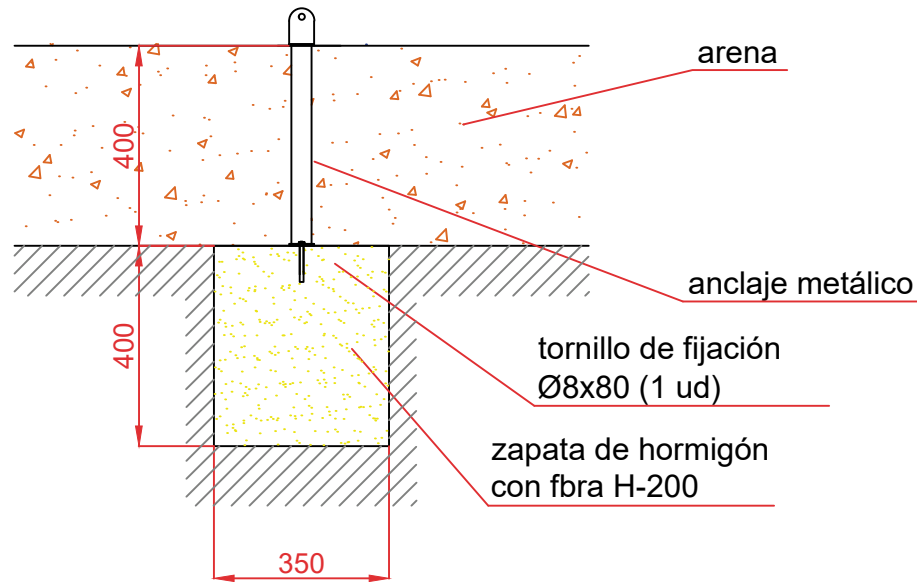

PLANTA CIMENTACIÓN



ESQUEMA DE CIMENTACIÓN
EN HORMIGÓN
E: 2/1

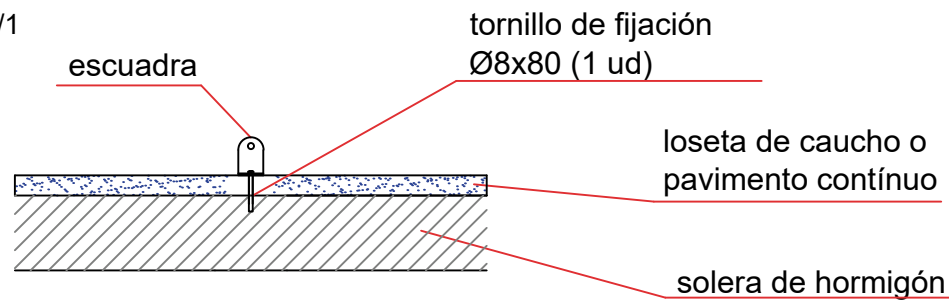

Dibujado		PLANO 2 CIMENTACIÓN Y ANCLAJES		Ref: TBG02
Revisado				
Aprobado				
Descripción:		TOBOGÁN "MANZANARES"	Escala:	Nº Hoja 3/4
			Fecha:	08/05/2019

ALZADO

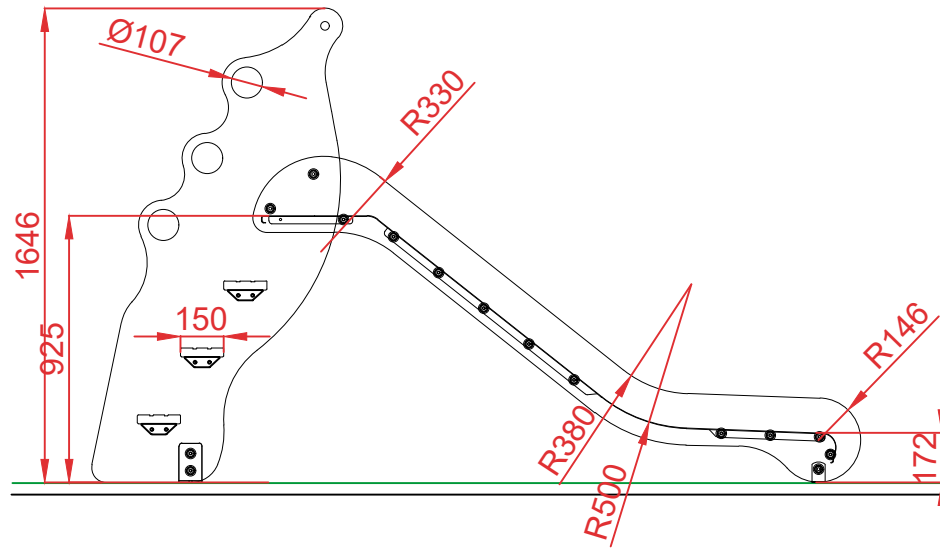

PERFIL

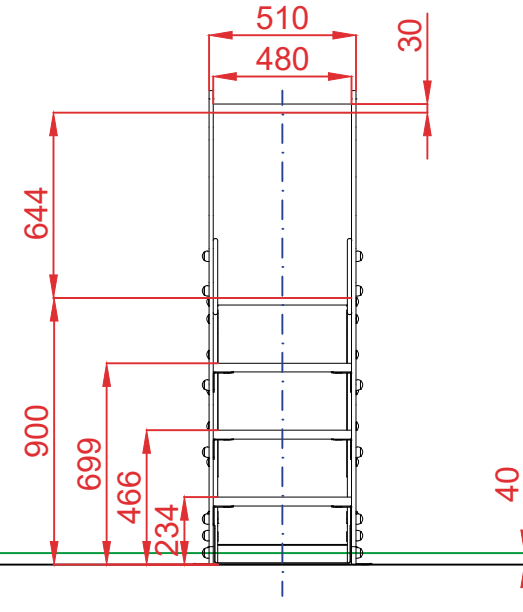

PLANTA

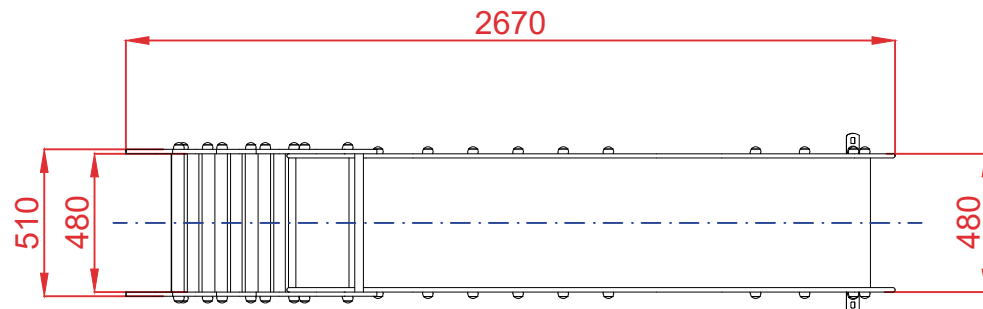

Dibujado		PLANO 3		Ref: TBG02
Revisado		VISTAS DE DETALLE		
Aprobado				
Descripción: TOBOGÁN "MANZANARES"		Escala:	Nº Hoja 4/4	
		Fecha:	08/05/2019	