

DOCUMENTACIÓN TÉCNICA

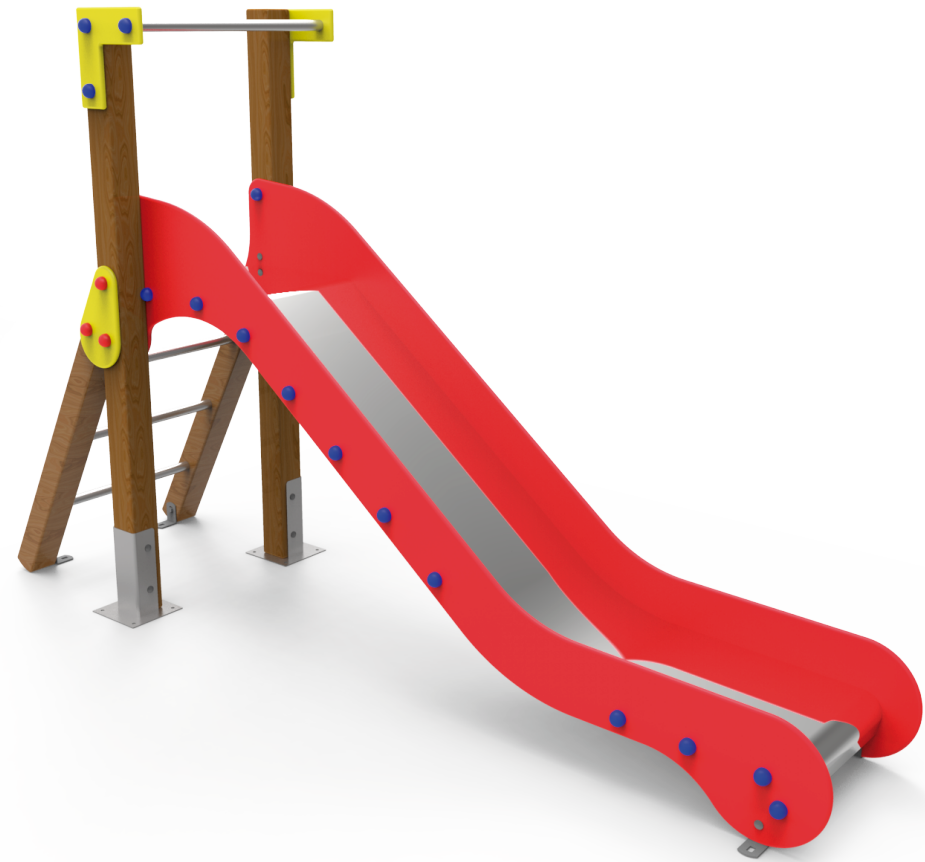
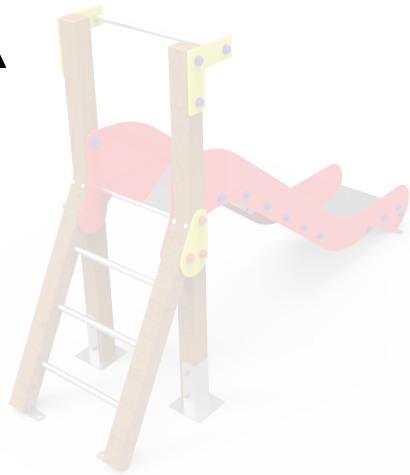

Ref.: TBG07

Tobogán "Quipar Mini"

UNE-EN 1176 -1:2018

UNE-EN 1176 -3:2018



Altura libre de caída: 0,90 m
Edad recomendada de uso: a partir de 3 años
Componentes plásticos: Polietileno de alta densidad con protección UV
Rampa de tobogán: acero inoxidable
Tubo superior: acero inoxidable
Tornillería protegida con tapones de polipropileno
Madera de pino tratada en autoclave Nivel IV

ALZADO

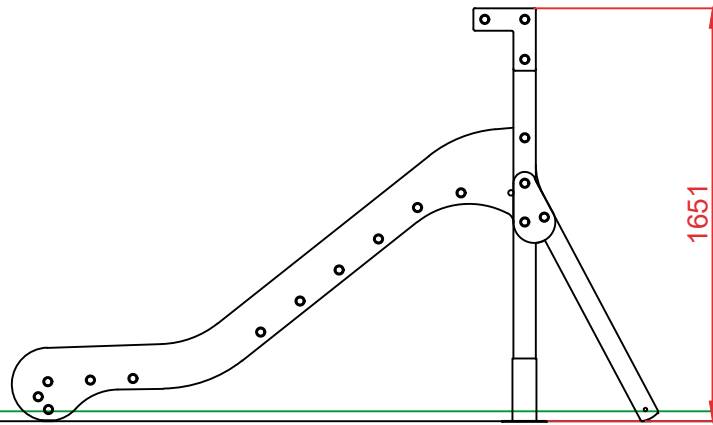

PERFIL

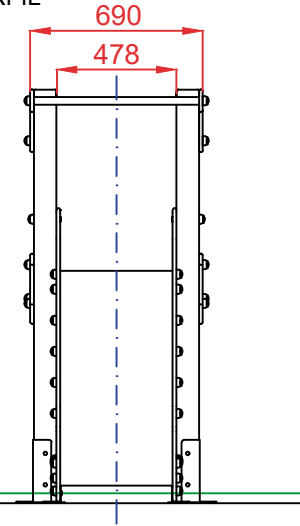

PLANTA

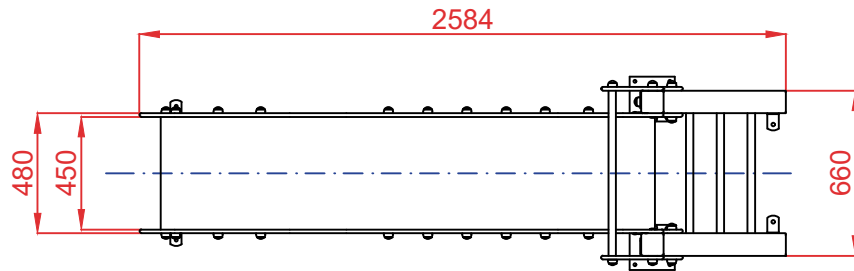

ÁREA DE SEGURIDAD
Superficie= 17.1 m²
E:1/2

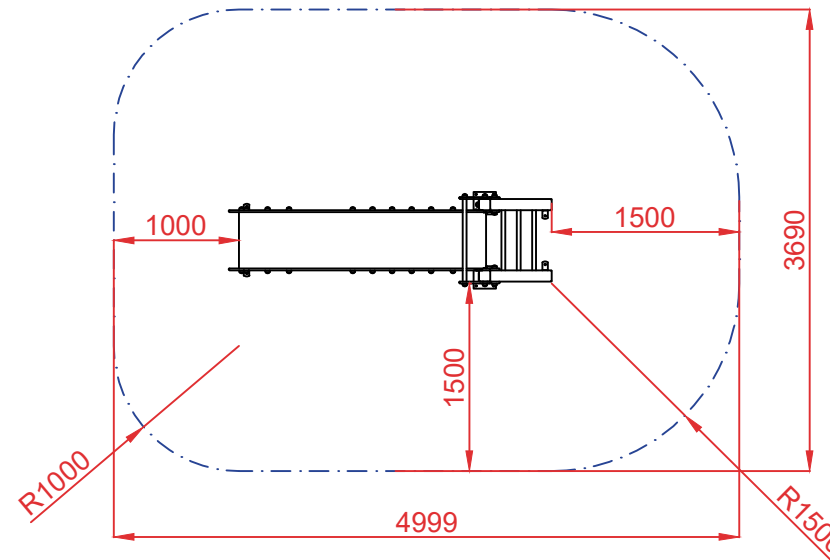

Dibujado		PLANO 1		Ref: TBG07
Revisado		VISTAS GENERALES		
Aprobado				
Descripción:		Escala:	Nº Hoja	
TOBOGÁN "QUIPAR MINI"			2/4	
		Fecha:	07/05/2019	

DETALLES CIMENTACIÓN

ESQUEMA DE CIMENTACIÓN
EN ARENA
E: 2/1

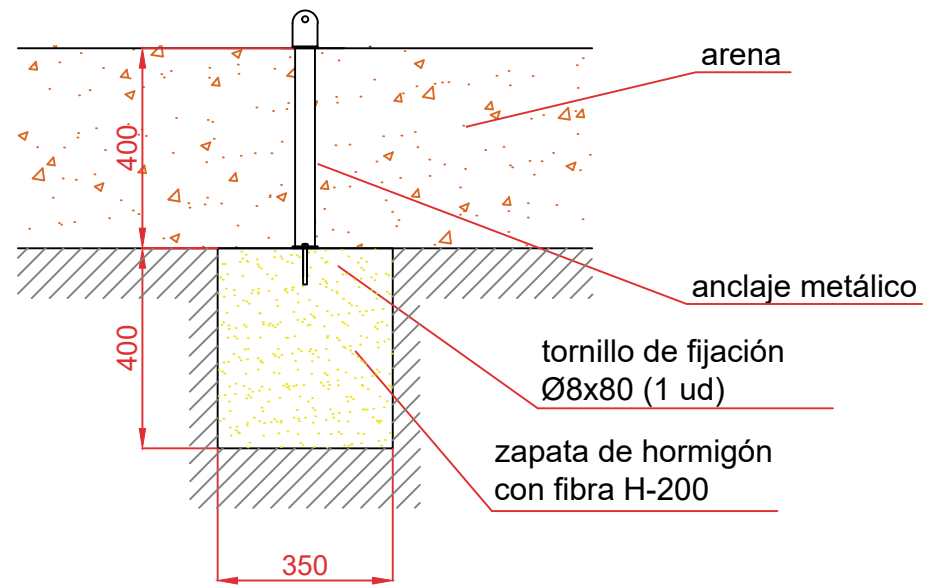

PLANTA CIMENTACIÓN

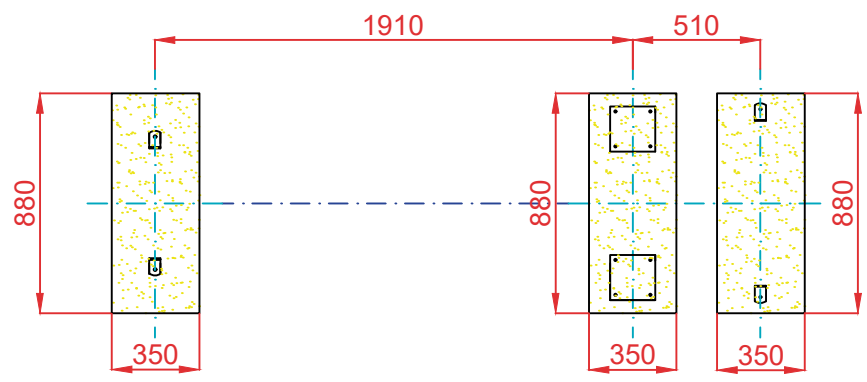

ESQUEMA DE CIMENTACIÓN
EN HORMIGÓN
E: 2/1

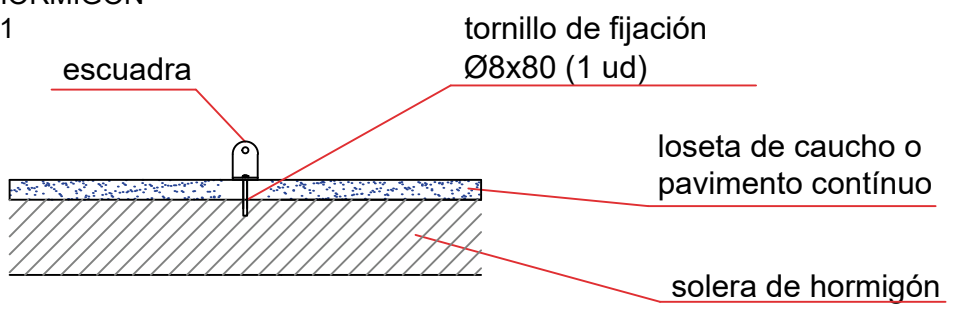

Dibujado		PLANO 2 CIMENTACIÓN Y ANCLAJES		Ref: TBG07
Revisado				
Aprobado				
Descripción:		TOBOGÁN "QUIPAR MINI"	Escala: N° Hoja 3/4	
			Fecha: 07/05/2019	

ALZADO

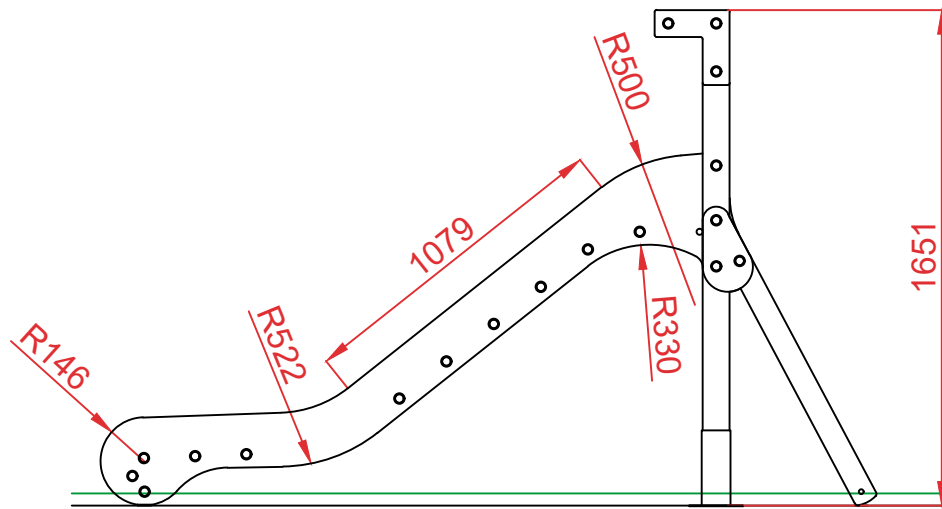

PERFIL

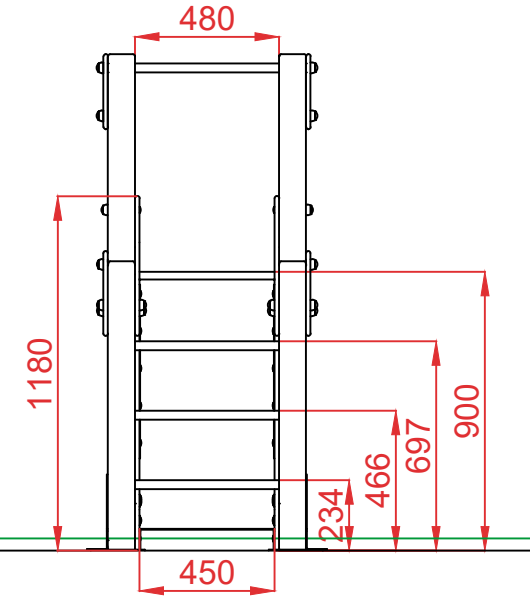

PLANTA

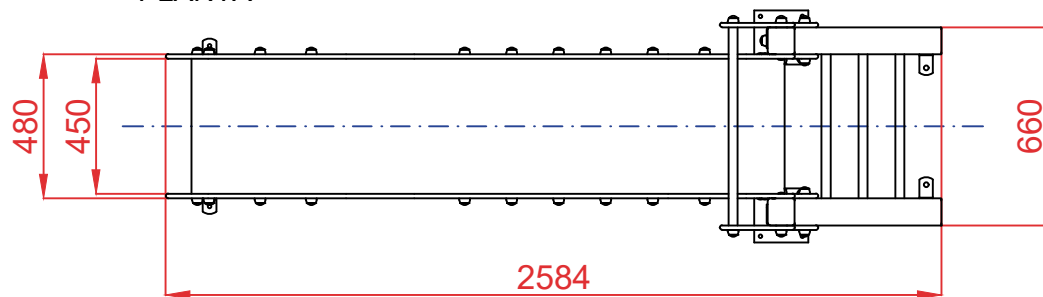

Dibujado		PLANO 3		Ref: TBG07
Revisado		VISTAS DE DETALLE		
Aprobado				
Descripción: TOBOGÁN "QUIPAR MINI"		Escala:	Nº Hoja 4/4	
		Fecha:	07/05/2019	