

DOCUMENTACIÓN TÉCNICA



Ref.: JRSMXT01

Torre Maxi "Dino 01"

UNE EN 1176-1:2018

UNE EN 1176-3:2018

Altura libre de caída: 1,36 m
Edad recomendada de uso: a partir de 3 años
Componentes plásticos: Polietileno de alta densidad con protección UV
Componentes metálicos galvanizados
Postes de madera tratada en autoclave Nivel IV
Tobogán con rampa de acero inoxidable
Tornillería protegida con tapones de polipropileno

ALZADO

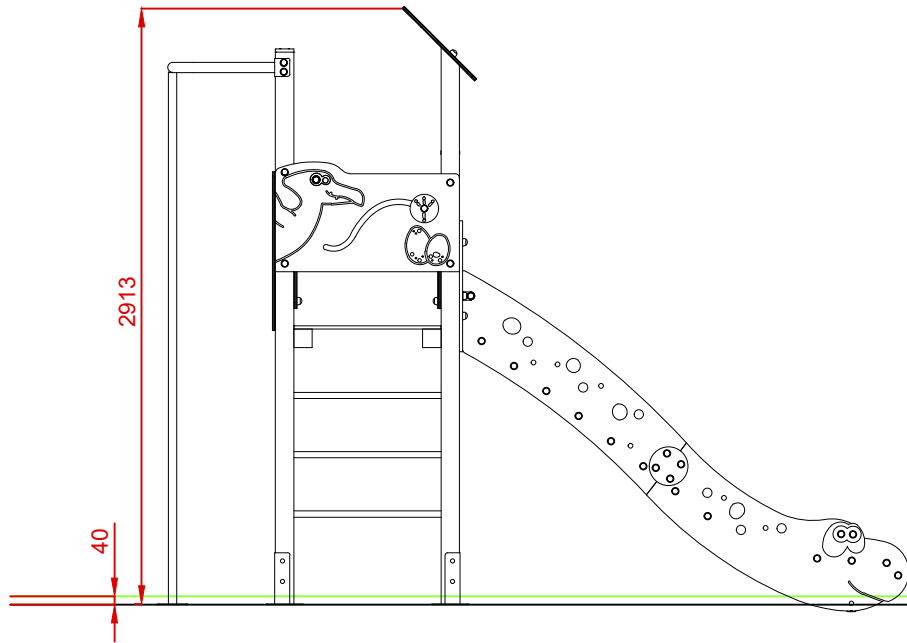

PERFIL

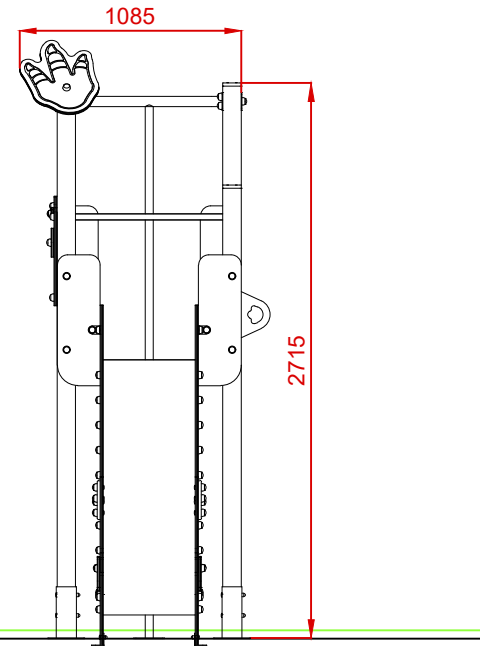

PLANTA

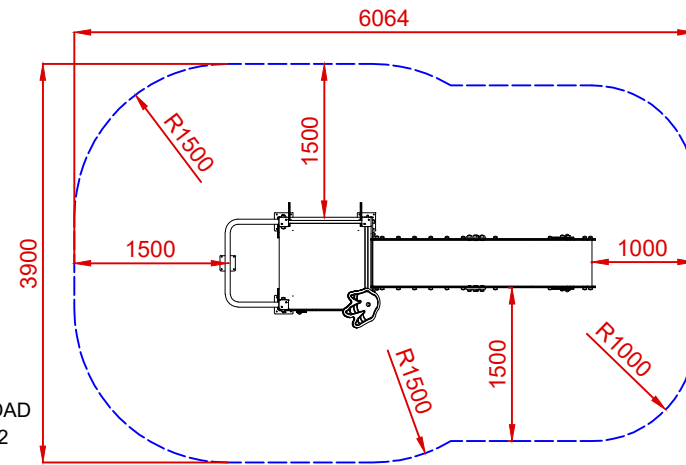
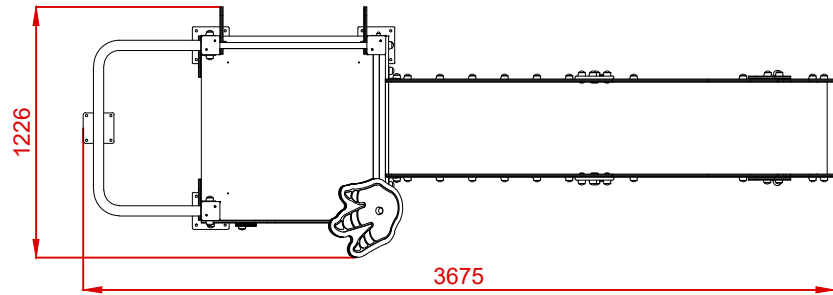

ÁREA DE SEGURIDAD
Superficie= 21,15 m2
E: 1/2

Dibujado		PLANO 1 VISTAS GENERALES		Ref: JRSMXT01
Revisado				
Aprobado				
Descripción:		Escala:	Nº Hoja	
TORRE MAXI "DINO 01"			2/4	
		Fecha:	16/10/2020	

DETALLES CIMENTACIÓN

ESQUEMA DE CIMENTACIÓN
EN ARENA

E: 2/1

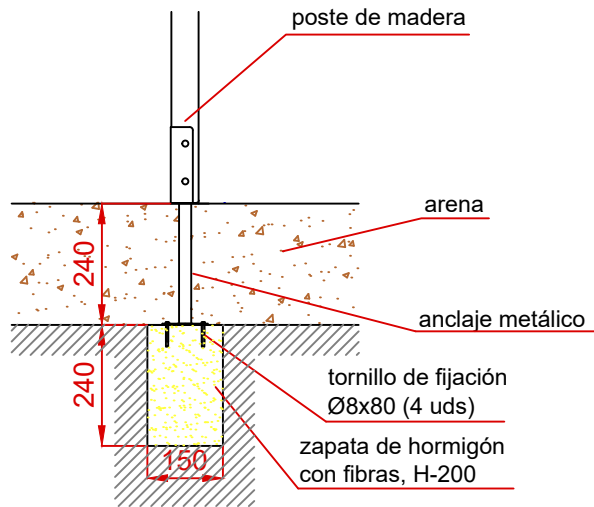

PLANTA CIMENTACIÓN

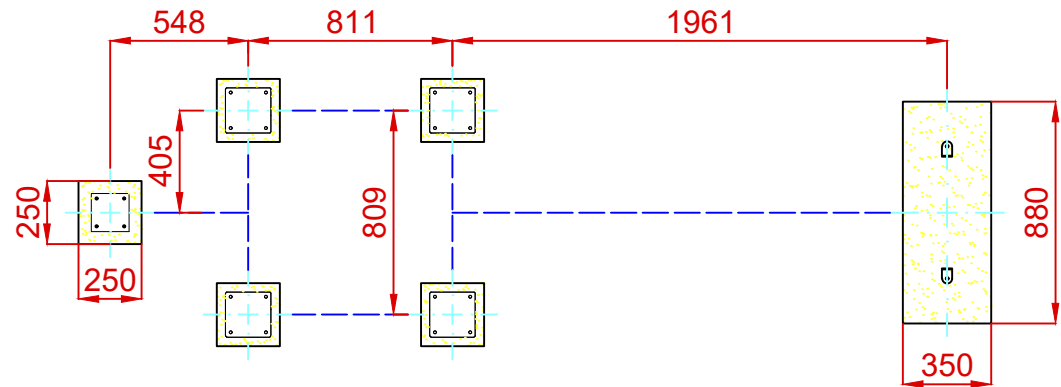

ESQUEMA DE CIMENTACIÓN
EN HORMIGÓN

E: 2/1

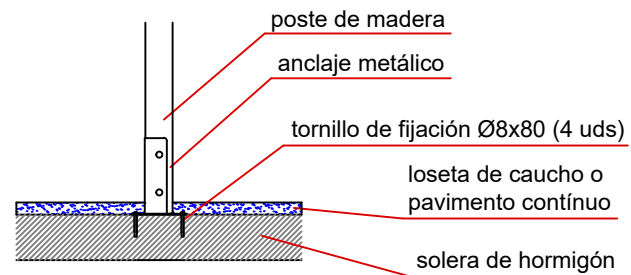

Dibujado		PLANO 2 CIMENTACIÓN Y ANCLAJES		Ref: JRSMXT01
Revisado				
Aprobado				
Descripción:		Escala:	Nº Hoja	
TORRE MAXI "DINO 01"			3/4	
		Fecha:	16/10/2020	

ALZADO

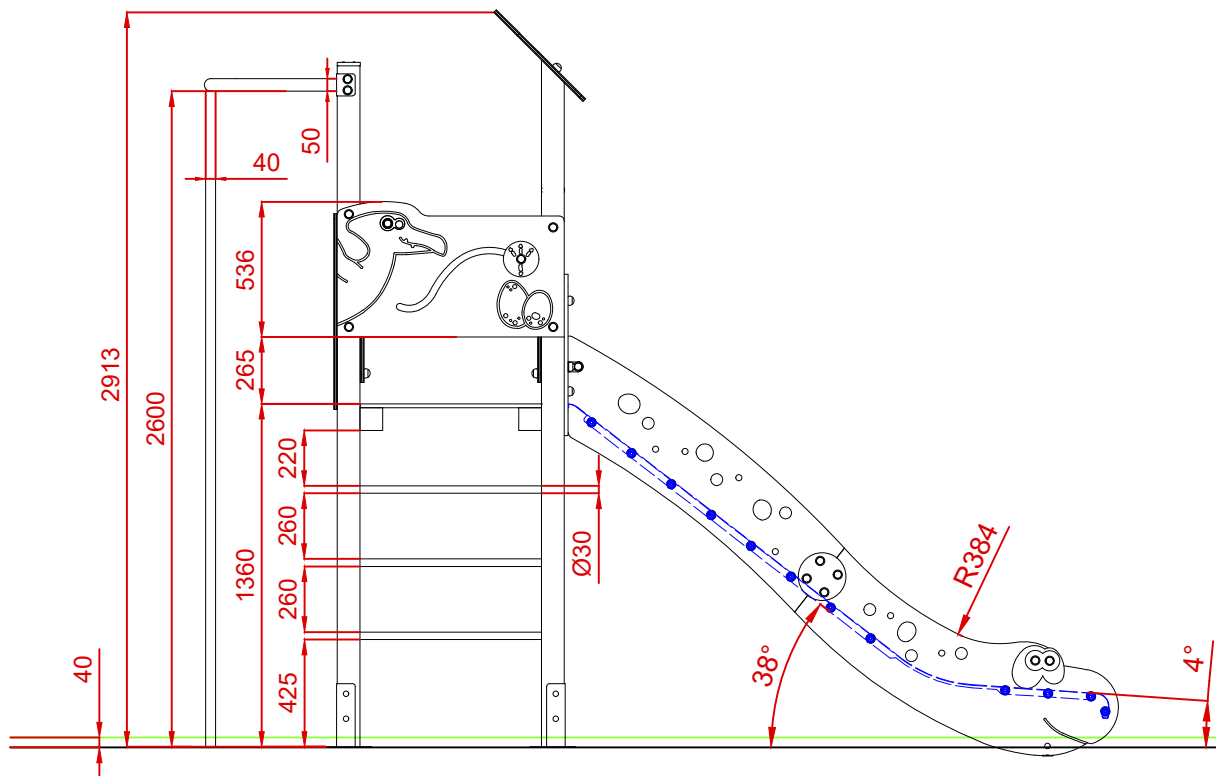

PERFIL

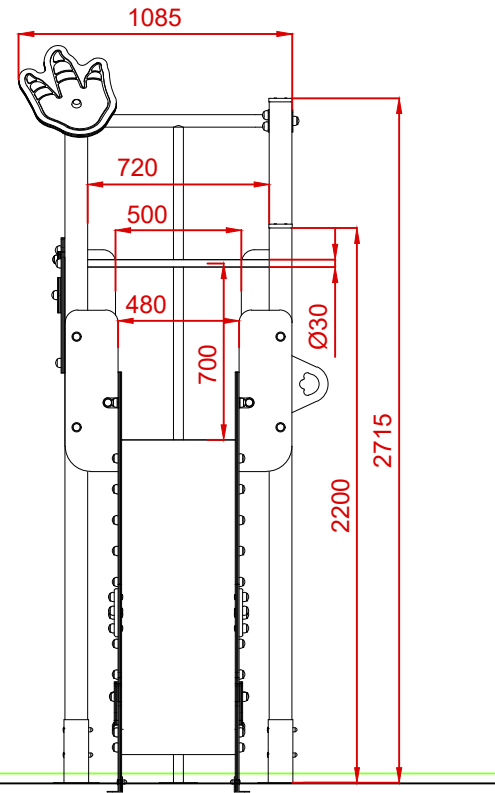

PLANTA

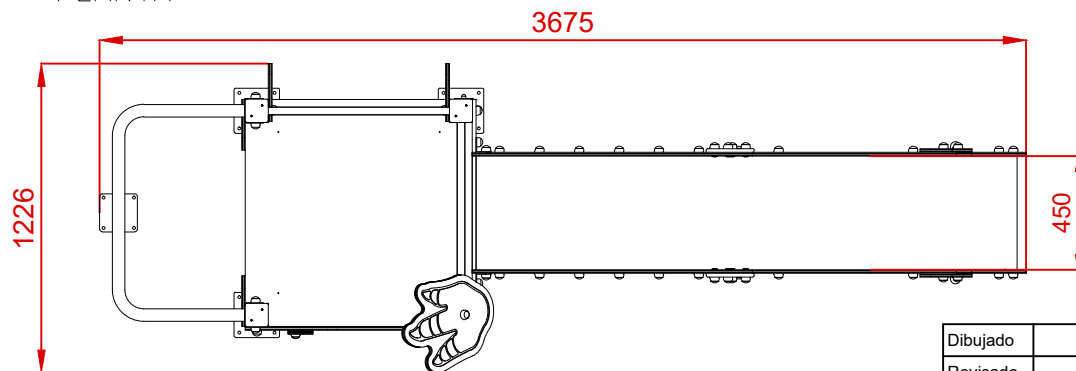

Dibujado		PLANO 3		Ref: JRSMXT01
Revisado		VISTAS DE DETALLE		
Aprobado				
Descripción:		Escala:	Nº Hoja	
TORRE MAXI "DINO 01"			4/4	
		Fecha:	16/10/2020	